

REVISIONS			
LTR	DESCRIPTION	DATE	APPROVED
IR	INITIAL RELEASE	3/15/2003	S.BROWN
A	ADDED SHT 10 FOR NOMEX FELT ON SIDEWALLS ADDED NOTE 8 TAPE WAS P/N: 425 ALUMINUM TAPE BY 3M. RENUMBERED PAGES. LOPA WAS ON SHT 9.	8/4/2003	S.BROWN

NOTES:

- UNLESS OTHERWISE SPECIFIED ALL DIMENSION TOLERANCES ARE ±0.5".
- BLANKET MATERIALS P/N: 53G2521522-101 AND 53G2521522-201 ARE TO BE CUT AND FITTED TO OUTBOARD FACE OF THE EXISTING LH AND RH DADO PANELS THAT RUN ON EACH SIDE OF PASSENGER CABIN FROM FORWARD CABIN PARTITION TO THE AFT CABIN PARTITION. BLANKETS ARE TO BE CUT AROUND ANY EXISTING EQUIPMENT OR OPENING'S (0.06 MIN GAP) DEPENDING ON AIRCRAFT CONFIGURATION. ALL CUT EDGES ARE TO BE SEALED USING ORCO TAPE P/N: 12206020.
- BLANKET MATERIALS P/N: 53G2521522-101 AND 53G2521522-201 ARE TO BE INSTALLED BELOW EXISTING CABIN CARPET UNDERLAY PADDING RUNNING FROM THE PILOT BULKHEAD TO THE AFT CABIN PARTITION. BLANKET SEAMS TO BE JOINED TOGETHER USING ORCO TAPE P/N: 12206020 TO FORM A SINGLE BLANKET. BLANKET TO FOLLOW APPROXIMATE CONTOUR OF CABIN INTERIOR MONUMENTS, PARTITIONS, SEATS, AND DIVANS AS APPLICABLE BY BEING CUT TO APPROXIMATE THE EXISTING CABIN CARPET(S) LEAVING SPACE FOR EXISTING CARPET(S) HOOK AND LOOP FASTENERS AS REQUIRED. BLANKETS TO BE CUT AROUND ANY EXISTING EQUIPMENT OR OPENINGS (0.06 MIN GAP) DEPENDING ON AIRCRAFT CONFIGURATION.
- BOND DAMPING MATERIAL TO EXISTING FLOOR PANELS USING A PORTION OF THE SELF ADHESIVE BACKING OF SD-40ALPSA MATERIAL ONLY AS SHOWN IN DETAIL AA. DO NOT ADD ADDITIONAL ADHESIVES. CUT DAMPING MATERIAL TO FIT EXISTING FLOOR PANELS AS SHOWN. CUTOUT DAMPING MATERIAL AS REQUIRED TO FIT EXISTING ACCESS PANELS IF APPLICABLE.

5. MATERIALS TO MEET THE REQUIREMENTS OF 14CFR 25.853(a) WHEN TESTED AS PER 14CFR PART 25, APPENDIX F, PART I.

6. FINAL QUANTITY OF BLANKETS (-101 & -201) WILL VARY DEPENDING ON APPLICABLE LOPA. QUANTITY SHOWN WILL COVER AREA FROM FS280 TO FS799 AND FULL WIDTH OF CABIN FLOOR. ADJUST FINAL QUANTITY AS REQUIRED FOR EACH LOPA.

7. ACCEPTABLE ALTERNATE TO APLIX HOOK AND LOOP FASTENER IS P/N: MP-3560, DUAL LOCK RECLOSABLE FASTENER BY 3M.

8. WIDTH FOR NOMEX FELT ON OUTBOARD FACE OF PSU MAYBE INCREASED TO INCLUDE ADDITIONAL OPEN AREAS ON THE OUTBOARD FACE OF THE PSU PANEL WHERE THE PSU CONFIGURATION PERMITS. CUT NOMEX FELT TO FIT AROUND EXISTING COMPONENTS WHILE MAINTAINING A MINIMUM .06 GAP AND ATTACH USING HOOK AND LOOP FASTENER AS SHOWN.

QTY	QTY	QTY	PART NO.	DESCRIPTION	MATERIAL	SPECIFICATION	SIZE
		2	A400R0025L958-I-1"	LOOP		APLIX	1" WIDE X 25YD
		2	A400R0025H958-I-1"	HOOK		APLIX	1" WIDE X 25YD
		1	MC8-4591B	NOMEX FELT INSULATION		TEX TECH INDUSTRIES	0.5THKx48Wx10YD
		2	SD-40ALPSA	DAMPING MATERIAL		EAR SPECIALTY COMP.	27" X 48"
AR	AR	AR	12206020	ORCO TAPE	OT-6	ORCON	2" WIDE X 60 YD
	1	1	53G2521522-201	BARRIER BLANKET			39" X 54.7 YD
18		7	53G2521522-101	BLANKET ASSY			38" X 60"
		1	-5	INSULATION BLANKET ASSY			
		1	-3	BARRIER BLANKET ASSY			
		1	-1	INSTALLATION			

UNSPECIFIED TOLERANCE FRACTIONS: ±1/32 ANGLES: ±.5° MACH, ± 2° FORMED DECIMALS: .X, .XX, .XXX FASTENER HOLES: ±.050 EDGE MARGIN: ±.050 "EQUALLY SPACED" TOLERANCE: ±.060 HOLE TOLERANCE PER NAS618 BEND RADII: ±.01 ON THICKNESS < .06, ±.03 ON THICKNESS > .06			UNLESS OTHERWISE SPECIFIED DIMENSIONS ARE IN INCHES DO NOT SCALE DRAWING DIMENSIONAL SYMBOLS AND TOLERANCES PER ANSI Y14.5M-1982 SURFACE TEXTURE PER ANSI/ASME B46.1-1985 INTERNAL CORNER RADII: .16/.19 EXTERNAL CORNER RADII: .00/.25 TYPICAL SURFACE FINISH: 125/			THE INFORMATION CONTAINED HEREIN IS PROPRIETARY TO AIMS INTERNATIONAL CORP. AND SHALL NOT BE REPRODUCED OR DISCLOSED IN WHOLE OR IN PART OR USED FOR ANY DESIGN OR MANUFACTURE, EXCEPT WHEN SUCH USER POSSESSES DIRECT, WRITTEN AUTHORIZATION FROM A.I.M.S. INTERNATIONAL CORP. A.I.M.S. INTERNATIONAL CORP. 300 Delaware Avenue, Wilmington, Delaware 19801 INTERIOR NOISE REDUCTION KIT INSTALLATION		
CONTRACT: GLOBAL EXPRESS			DRAWN: S.BROWN CHECKED: J.SANZ STRESS: J.SANZ APPROVED:			DWG NO: 53G2521522 REV A SCALE: SHOWN SHEET 1 OF 10		

DWG NO 53G2521522 SH 1 REV A

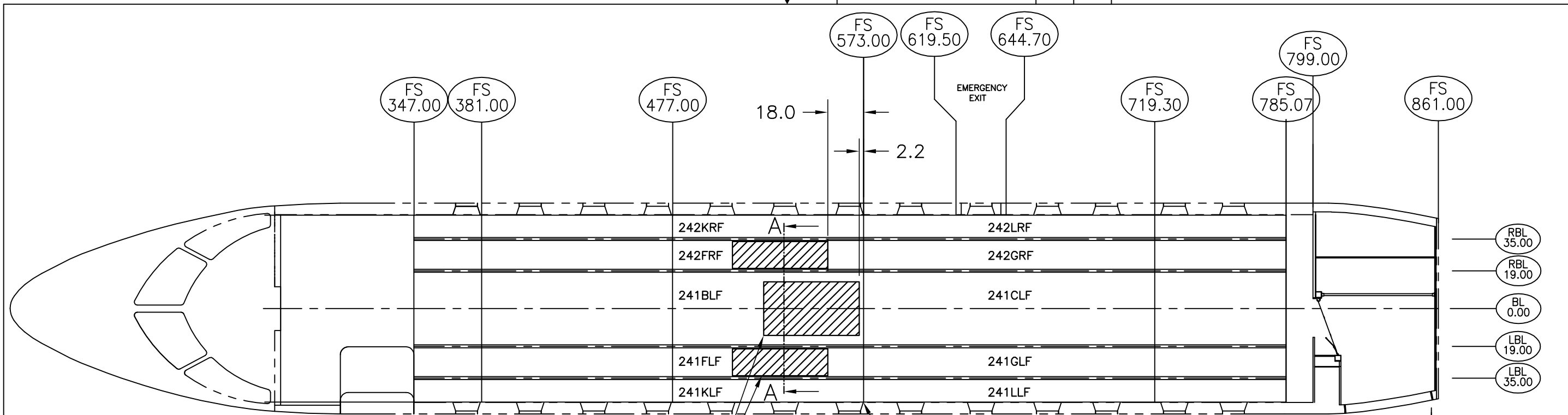

FABRICATE USING
(2) TWO SHEETS
OF SD-40ALPSA
DAMPING MATERIAL
SEE DTL AA.

DAMPING MATERIAL INSTL

SEE NOTE 4.
VIEW ON CABIN FLOOR PANELS
SCALE: NTS

SD-40ALPSA DAMPING MATERIAL
INSTALL BEFORE INSTALLING
-3 BARRIER AND -5 INSULATOR
BLANKET ASSEMBLIES PER NOTE 4.

EXIST FLOOR PANEL

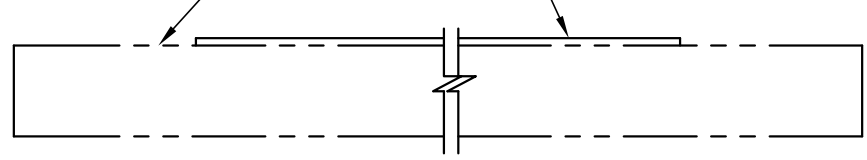

SECTION A-A
TYPICAL FLOOR PANEL SECTION
SCALE: NTS

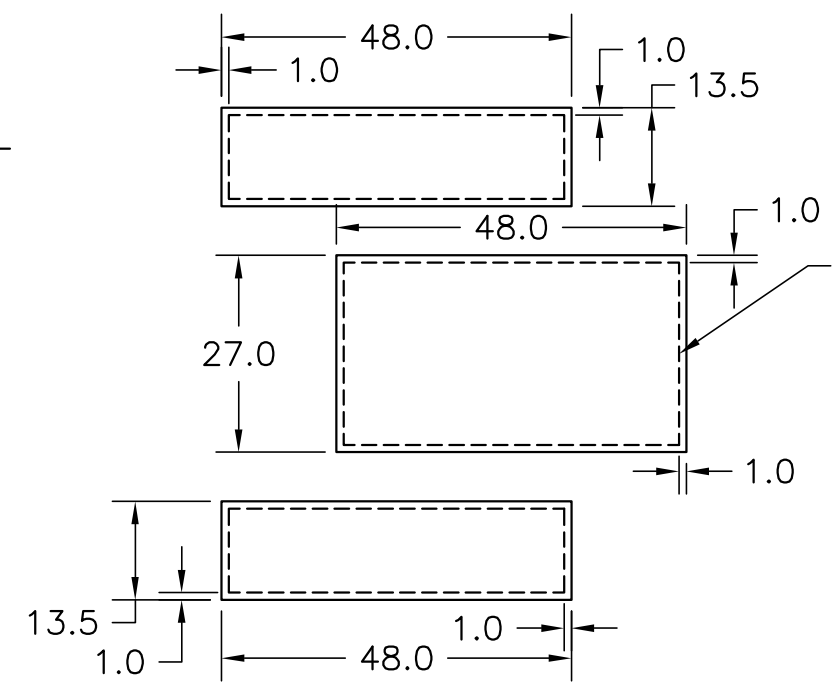

DETAIL AA
SCALE: NTS

SIZE B		DWG NO 53G2521522	REV A
SCALE SHOWN	SHEET 2 OF 10		

CUT WIDTH OF BARRIER BLANKET AS REQUIRED PER NOTE 3.
 INSTALL 12206020 ORCO TAPE ON ALL SEAMS
 SEE DETAIL B

FS 619.50
 FS 644.70
 EMERGENCY EXIT

FS 799.00
 FS 861.00

RBL 35.00
 RBL 19.00
 BL 0.00
 LBL 19.00
 LBL 35.00

D
 D
 SEE SHEET 6

53G2521522-201 BARRIER BLANKET
 PATTERN SHOWN MAY BE ALTERED TO SUIT
 EXISTING CABIN ARRANGEMENT PER NOTE 3.
 INSTALL ON TOP OF EXISTING FLOOR PANELS
 WITH ALUMINIZED FACE DOWN.

BAGGAGE DOOR
 FS 815.50
 FS 858.50

FS 280.00
 ENTRANCE
 FS 310.00
 FS 347.00

-3 BARRIER BLANKET
 SEE SHEET 5 & NOTE 3.
 VIEW ON CABIN FLOOR
 SCALE: NTS

INSTALL 12206020 ORCO TAPE SYMMETRICAL
 ABOUT C.L. OF BUTT JOINT WITH
 MINIMUM OVERLAP OF 0.5 FROM
 BUTT JOINT TO EDGE OF TAPE.

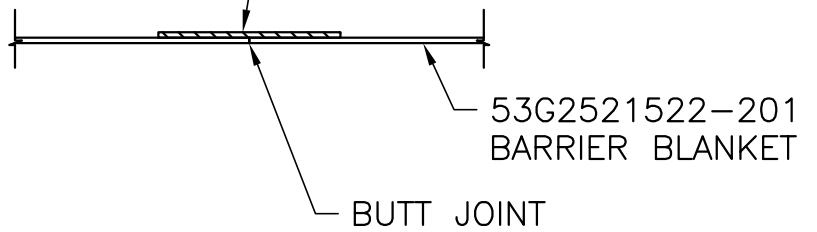

TYPICAL BLANKET SEAM
 DETAIL B
 SCALE: NTS

SIZE B		DWG NO 53G2521522	REV A
SCALE SHOWN	SHEET 3 OF 10		

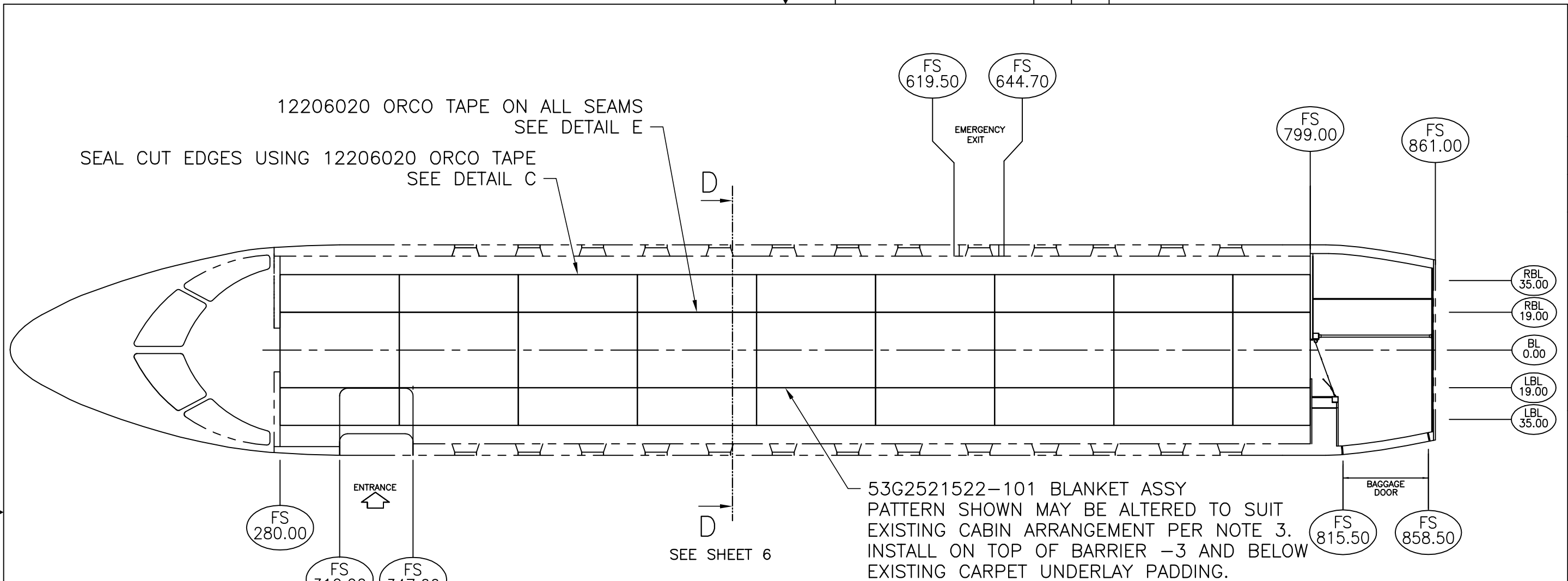

-5 INSULATION BLANKET ASSY

SEE SHEET 5 AND NOTE 3.
SCALE: NTS

INSTALL 12206020 ORCO TAPE SYMMETRICAL
ABOUT C.L. OF BUTT JOINT WITH
MINIMUM OVERLAP OF 0.5 FROM
BUTT JOINT TO EDGE OF TAPE.

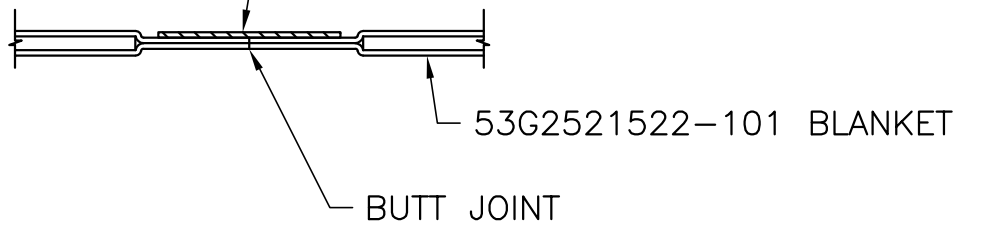

TYPICAL BLANKET SEAM
DETAIL E
SCALE: NTS

INSTALL 12206020 ORCO TAPE SYMMETRICAL
ABOUT EDGE OF BLANKET WITH
MINIMUM OVERLAP OF 0.5 FROM
EDGE OF BLANKET TO EDGE OF TAPE.

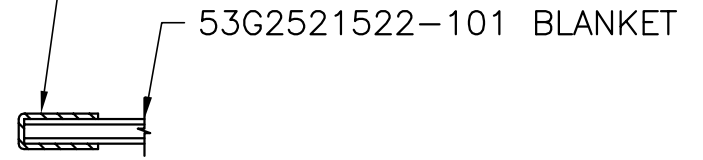

TYPICAL CUT EDGE
DETAIL C
SCALE: NTS

SIZE B		DWG NO	53G2521522	REV A
SCALE SHOWN		SHEET 4 OF 10		

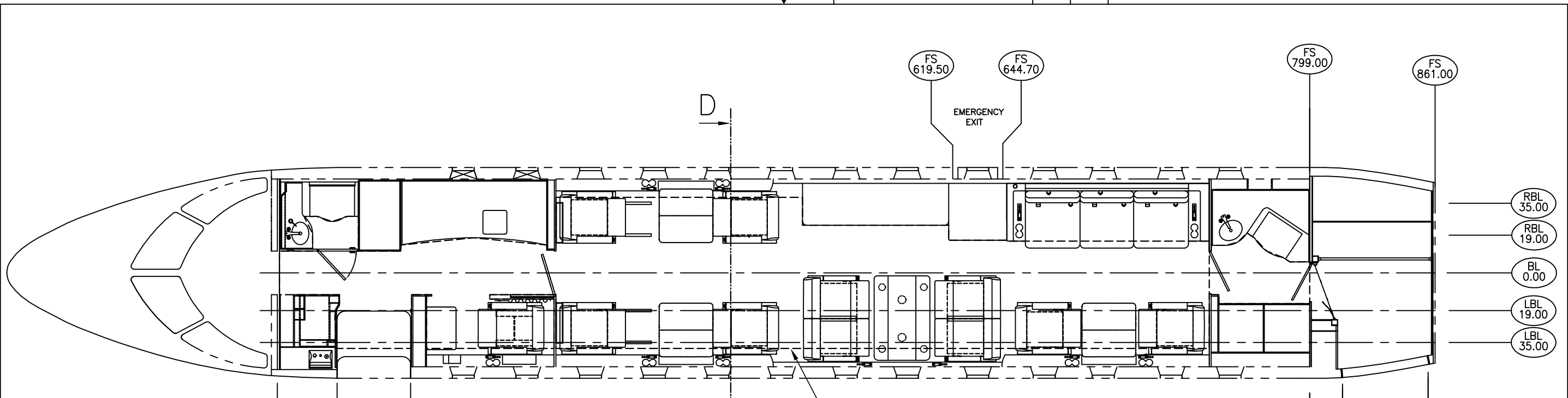

ENTRANCE

EMERGENCY EXIT

BAGGAGE DOOR

-3 & -5 BLANKET

-1 INSTALLATION
GENERAL ARRANGEMENT

TYPICAL FLOORPLAN SHOWN AS EXAMPLE
FINAL CONFIGURATION AS PER APPLICABLE AIRCRAFT LOPA.
SCALE: NTS

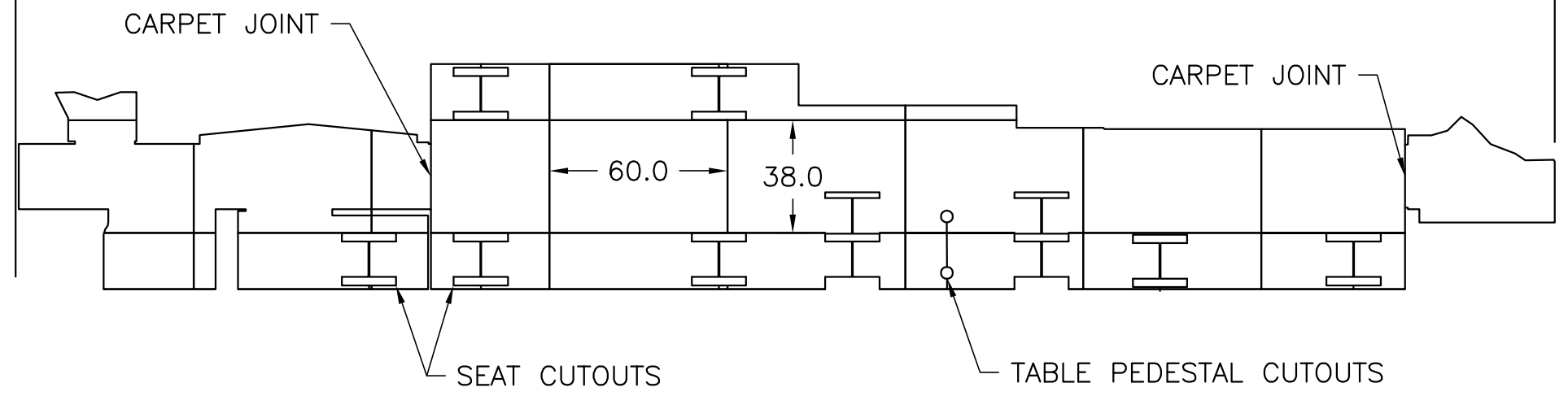

-3 & -5 BLANKET ASSY

FINAL CUT SHAPE SHOWN SEE NOTE 3.
TYPICAL FLOORPLAN SHOWN AS EXAMPLE
FINAL CONFIGURATION AS PER APPLICABLE LOPA.
SCALE: NTS

SIZE B		DWG NO 53G2521522	REV A
SCALE SHOWN	SHEET 5 OF 10		

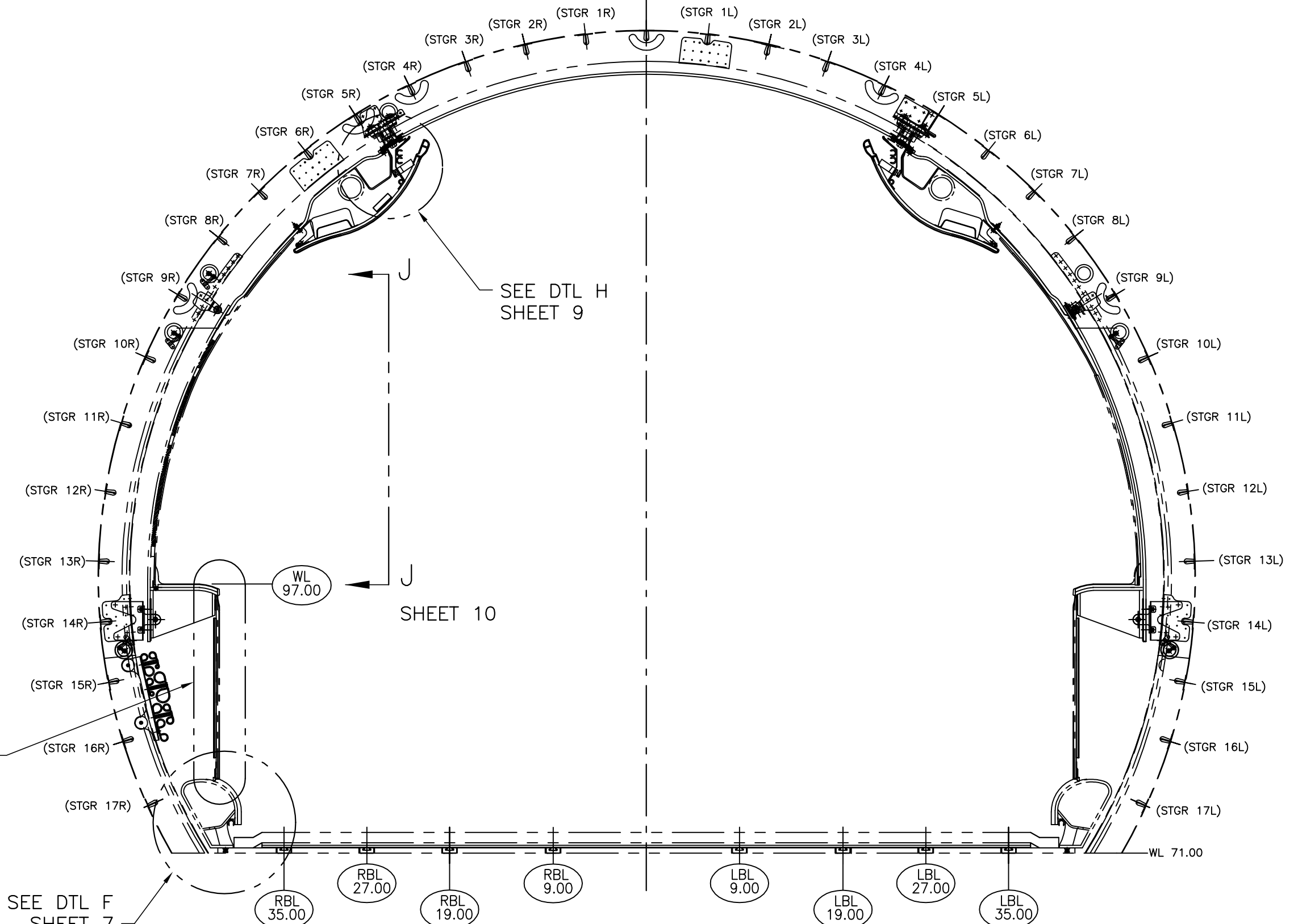

SECTION D-D
LOOKING AFT

SEE DTL G
SHEET 8

SEE DTL F
SHEET 7

SHEET 10

SEE DTL H
SHEET 9

SIZE B		DWG NO 53G2521522	REV A
SCALE SHOWN	SHEET 6 OF 10		

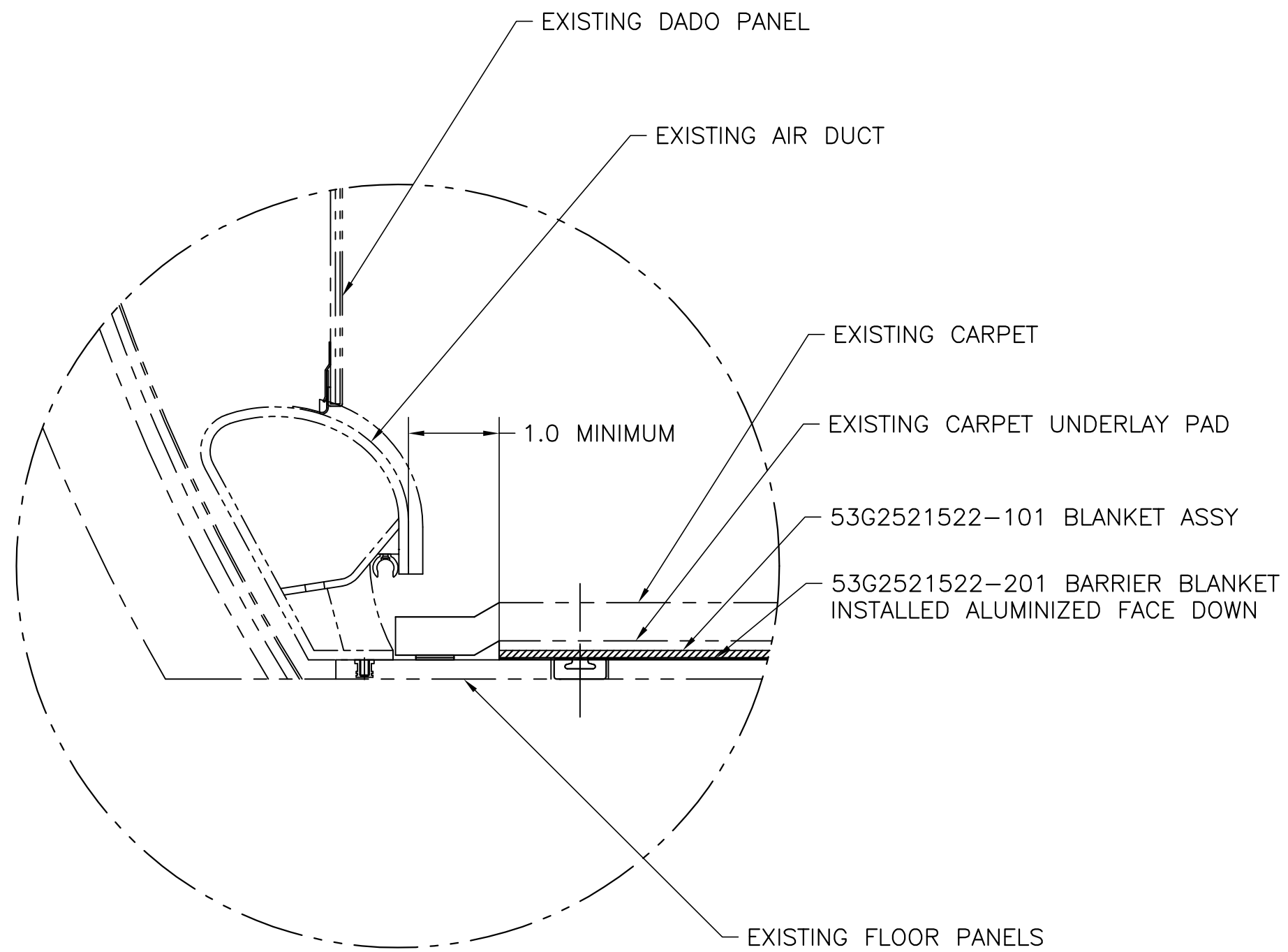

UP
OUTBD

DETAIL F
RHS SHOWN, LHS OPP.
SCALE: NTS
REF SHEET 6

SIZE B		DWG NO	53G2521522	REV A
SCALE	SHOWN	SHEET 7 OF 10		

12206020 ORCO TAPE
FASTEN BOTH BLANKETS TO
DADO PANEL ON ALL EDGES
OF BOTH BLANKETS.
SEE NOTE 2.

53G2521522-101 BLANKET ASSY
INSTALL BETWEEN BARRIER
BLANKET AND DADO PANEL.
SEE NOTE 2.

53G2521522-201 BARRIER BLANKET
INSTALL ON OUTBOARD SIDE WITH
ALUMINIZED FACE FACING OUTBD.
SEE NOTE 2.

12206020 ORCO TAPE
FASTEN BOTH BLANKETS TO
DADO PANEL ON ALL EDGES
OF BOTH BLANKETS.
SEE NOTE 2.

EXISTING DADO MTG CLIPS

EXISTING DRINK RAIL(S)

EXISTING DADO PANEL VELCRO

EXISTING DADO PANEL(S)

EXISTING AIR DUCT



UP

OUTBD

DETAIL G

RHS SHOWN, LHS OPP
SCALE: NTS
REF SHEET 6

SIZE B		DWG NO	53G2521522	REV A
SCALE	SHOWN	SHEET 8 OF 10		



ENLARGE EXISTING VENTILATION HOLES IN COMPOSITE AIR DUCT FROM $\phi 0.50$ TO $\phi 0.75$ ALONG FULL LENGTH OF CABIN SIDEWALLS.

EXISTING HEADLINER PANEL

EXISTING HANDRAIL

EXISTING AIR DUCT

SEE NOTE 8

EXISTING PSU PANEL

2.0

FABRICATE NOMEX FELT PAD USING P/N: MC8-4591 INSTALL FULL LENGTH OF CABIN PSU PANELS

ATTACH FELT TO PSU PANEL(S) USING 1" X 2" STRIPS OF HOOK P/N: A400R0025H958-I-1" LOOP: P/N: A400R0025L958-I-1" SPACED AT 1" FROM ENDS AND AT 6" TO 18" CENTERS.

UP

OUTBD

DETAIL H
RHS SHOWN, LHS OPP.
SCALE: NTS
REF SHEET 6

SIZE B		DWG NO 53G2521522	REV A
SCALE SHOWN	SHEET 9 OF 10		

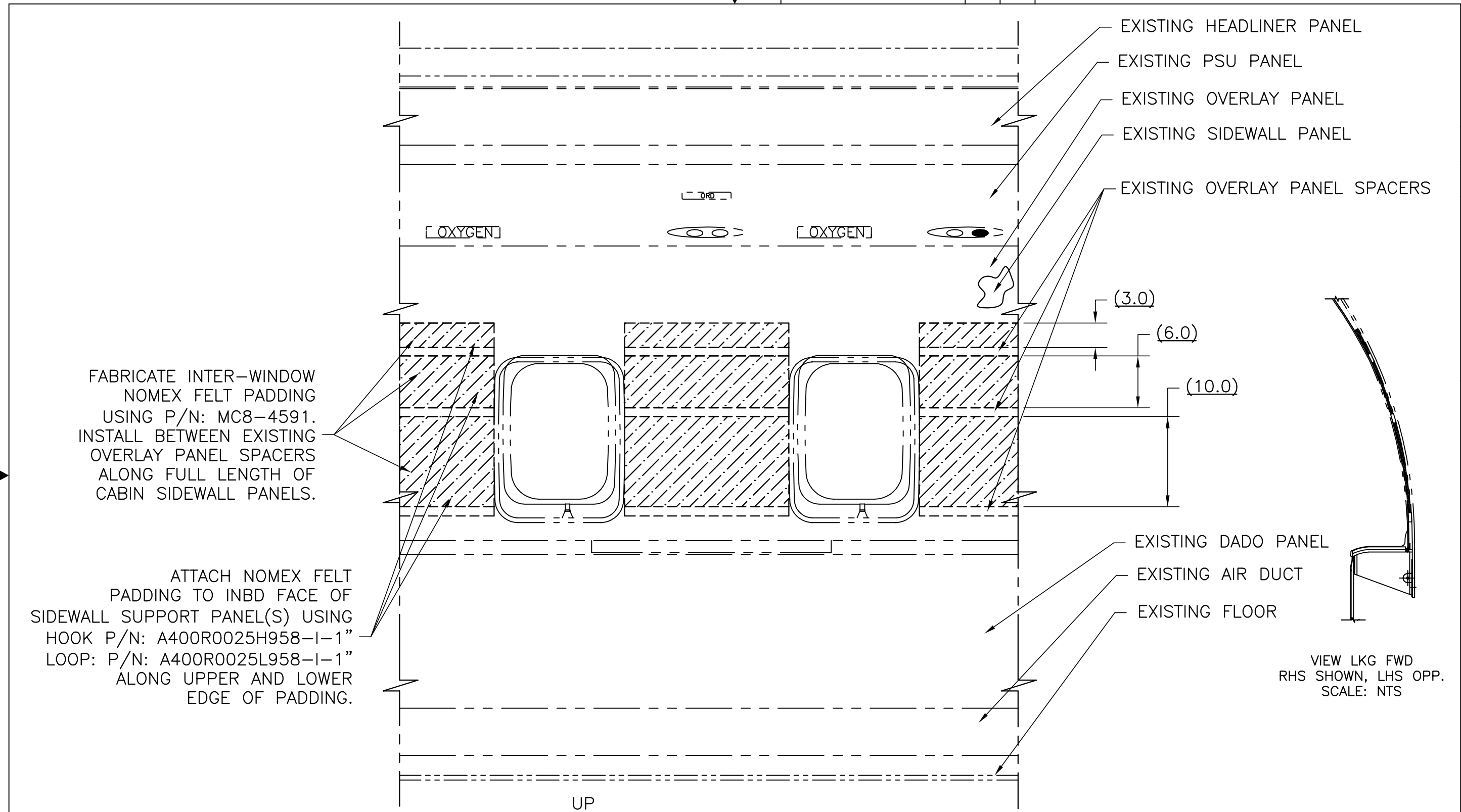

FABRICATE INTER-WINDOW
NOMEX FELT PADDING
USING P/N: MC8-4591.
INSTALL BETWEEN EXISTING
OVERLAY PANEL SPACERS
ALONG FULL LENGTH OF
CABIN SIDEWALL PANELS.

ATTACH NOMEX FELT
PADDING TO INBD FACE OF
SIDEWALL SUPPORT PANEL(S) USING
HOOK P/N: A400R0025H958-I-1"
LOOP: P/N: A400R0025L958-I-1"
ALONG UPPER AND LOWER
EDGE OF PADDING.

VIEW LKG FWD
RHS SHOWN, LHS OPP.
SCALE: NTS

VIEW J-J
RHS SHOWN, LHS OPP.
SCALE: NTS
REF SHEET 6

SIZE B		DWG NO	53G2521522	REV A
SCALE	SHOWN	SHEET 10 OF 10		